

AeraMax

Professional air purifier



Protect and disinfect the environment of your Boar Stud without ozone, neither UV, nor chemical, 24 hours a day.

Its concept unites deionisation and Hepa filters to eliminate effectively viruses, bacteria, allergens or odors

It is not enough to clean the superficies
**If the air is not clean,
your facilities don't either**



AeraMax

Professional air purifier

COMPACT, MODERN DESIGN AND EASY TO INSTALL

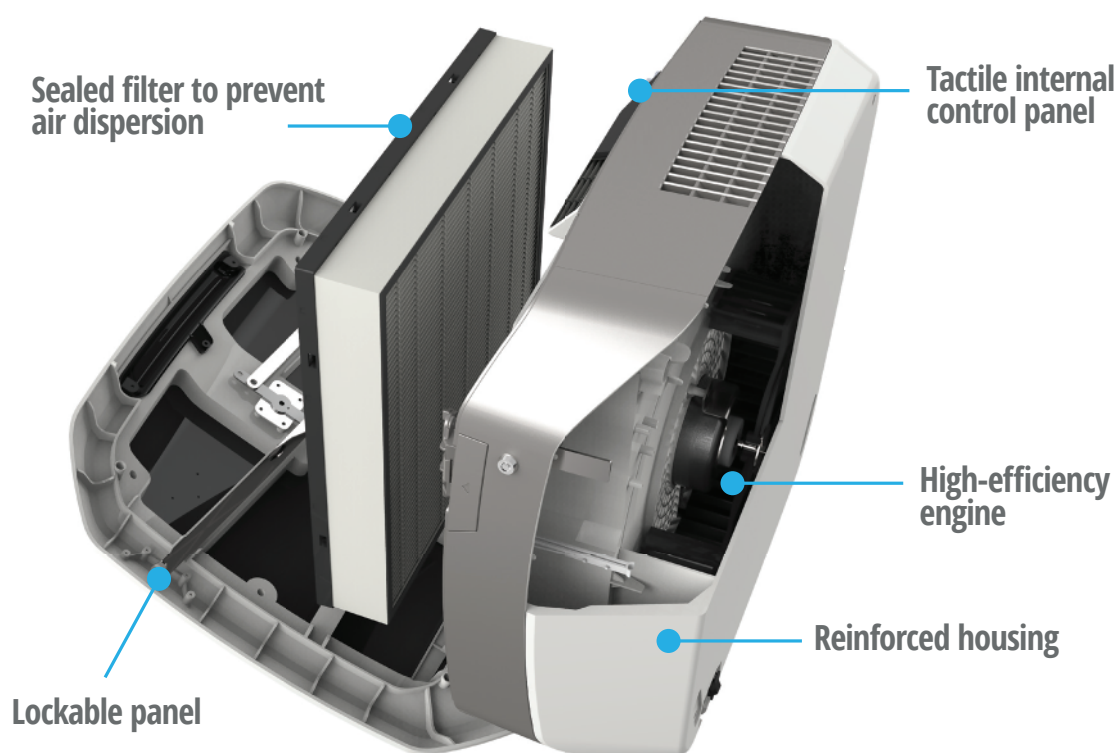

The **installation** is limited to anchoring AeraMax to one of the walls of the room, about 30 cm from the ceiling.

Its intelligent software detects when filters need to be changed, alerting the user and making the **maintenance** is **fast and simple**.

The **design** integrates perfectly into any space where it is necessary to purify the air.

Once installed you just have to choose the configuration that best suits your needs and forget that it is there.

WHERE CAN I USE AERAMAX?

● Clean-dirty areas

Contributes to the biosafety of the Boar Stud from the staff entrance, installing AeraMax on the changing room area and access to your facilities.

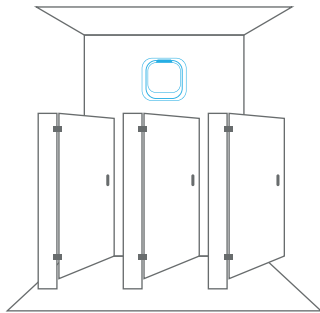

● Collection room

Installing AeraMax in the collection area, decreases levels of pollution, from the timing of the extraction.

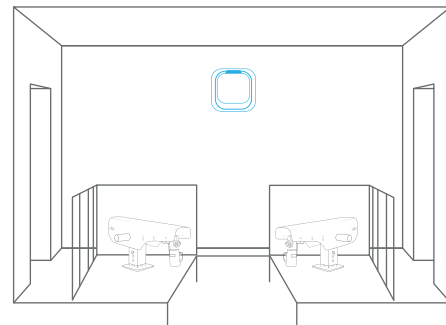

● Laboratory

The effect of AeraMax in the laboratory allows the preparation of doses to occur in a pure environment, free of bacteria and contaminants.

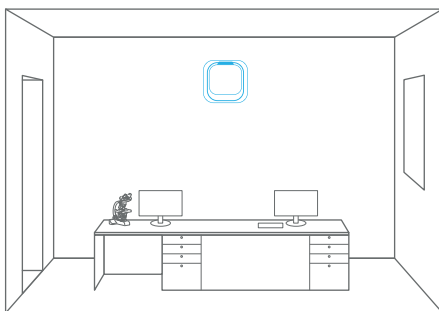

● Transitional or shared use stays

Areas where both center staff access as external personnel, whether logistics personnel, dose distributors or suppliers.

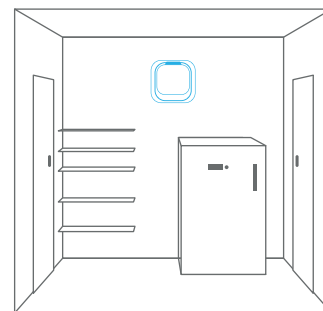

IDEAL FOR STAYS BETWEEN 30 AND 65 M²

Due to its high performance, AeraMax is able to purify, on its own, the atmosphere of the rooms that we find in most Boar Studs.



CAPABLE OF FILTERING UP TO 375 M³ OF AIR PER HOUR

The 5 speeds that the AeraMax fan integrates are controlled by its sensors to keep the rooms in an optimal state.

AeraMax

Professional air purifier

HOW IT WORKS

- 1 A **Pre-filter** captures and removes large particles and contaminants.
- 2 **Carbon filter** adsorbs* odors and chemicals.
- 3 **True HEPA** filtration traps **99.97%** of any remaining airborne pollutants**
- 4 The **Ionization system** electrically charges the particles to make them bigger and easier to filter.

Anti-microbial treatment e HEPA filter effectively reduces the development of bacteria and fungi on the filter.

*retains inside filter
**up to 0.3 microns

Intelligent sensors detect sound, motion and odor to assess a room's occupancy and condition, automatically adjusting to optimize performance, reduce energy consumption and extend filter life.

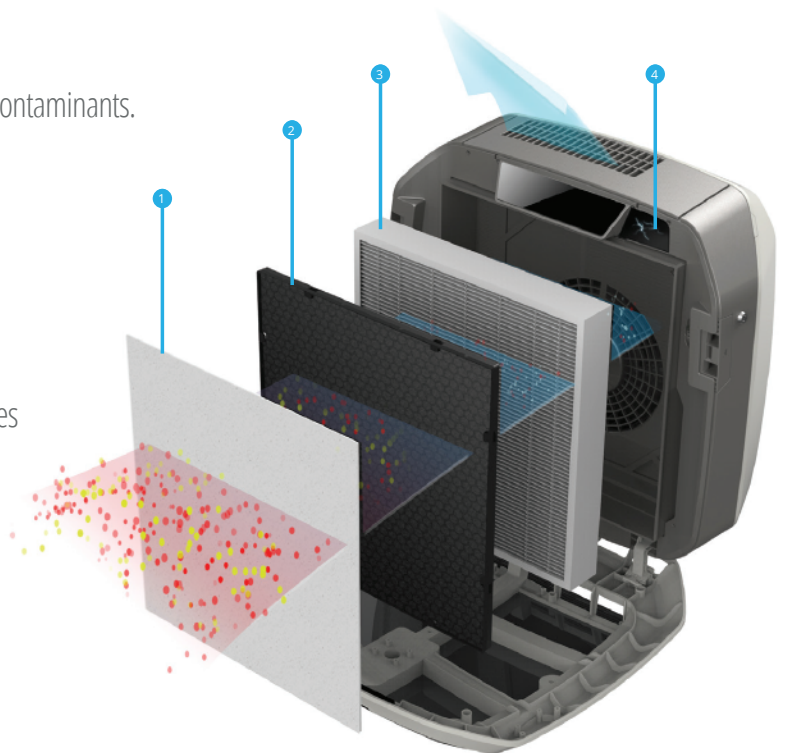

🔊 **Quiet mode**

🔊 **Normal mode**



HYGIENE IN THE COLLECTION AREA

Clean and pollution-free air contributes to the maximum hygiene of the seminal doses during the collection process.



LABORATORY SAFETY

AeraMax purifies virus, germs and bacteria in the air, maintains a constant quality and eliminate odors.



SMART TECHNOLOGY

Thanks to its presence and air quality detection system, it works according to the surrounding conditions, optimizing its consumption.