

# AMBIC®

## PeraSpray™

Fig. 1

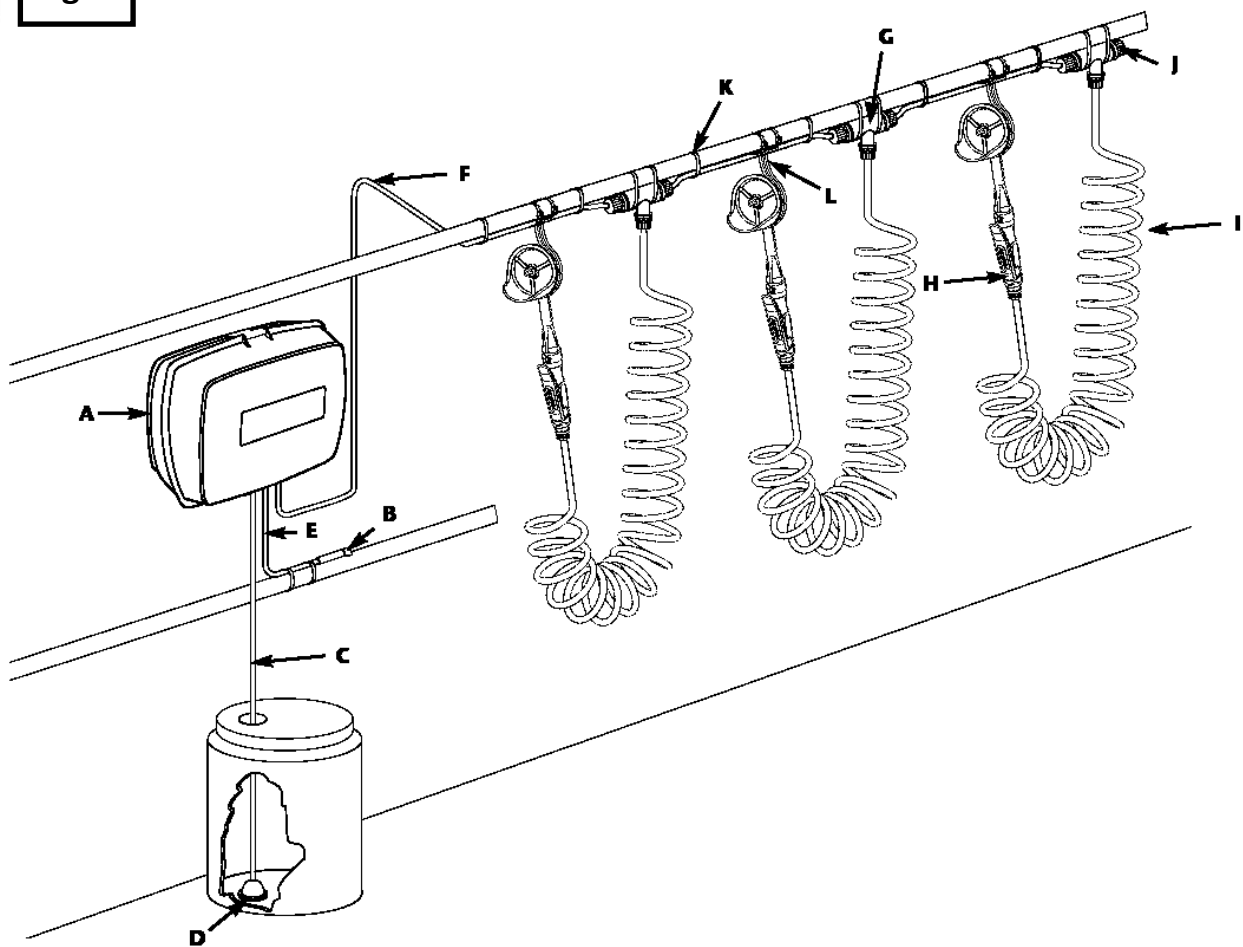

## OPERATING INSTRUCTIONS

Mode d'emploi • Istruzioni • Anleitung  
Instructies • Instrucciones

*leading best practice in livestock health management*

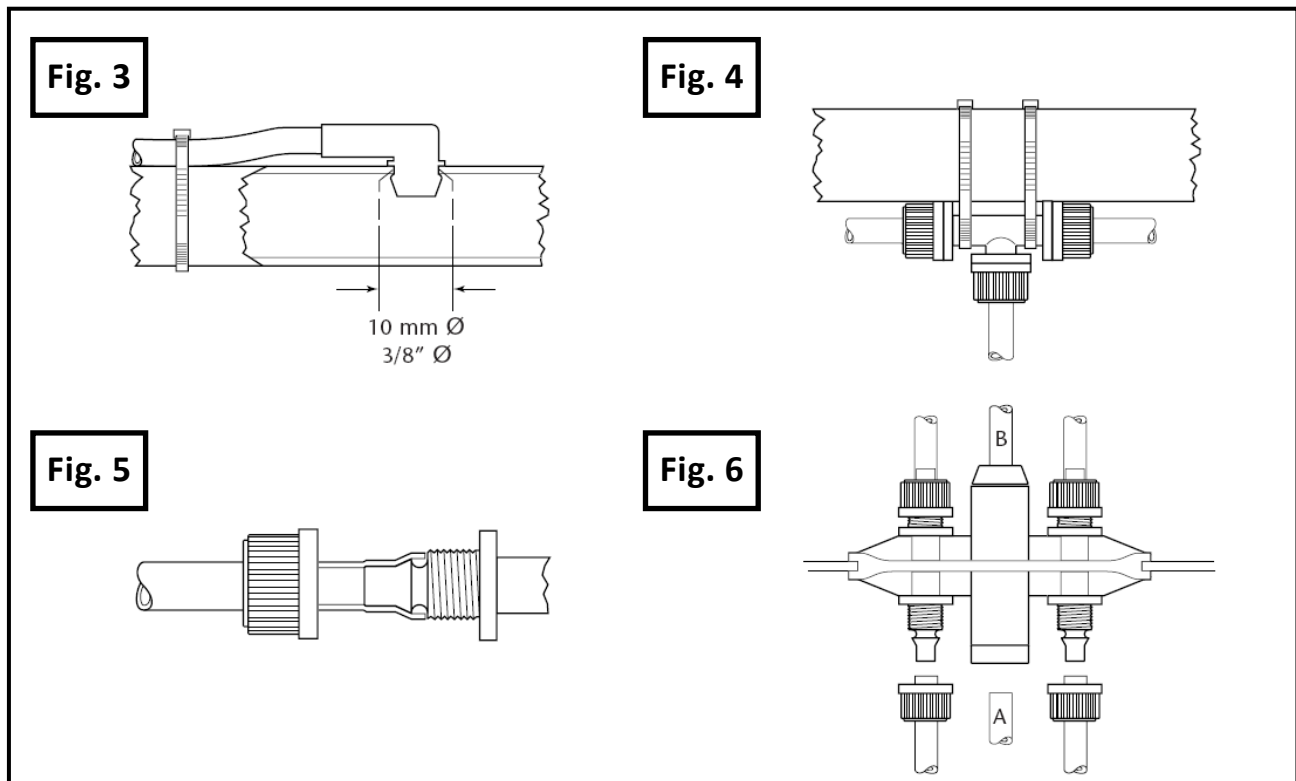
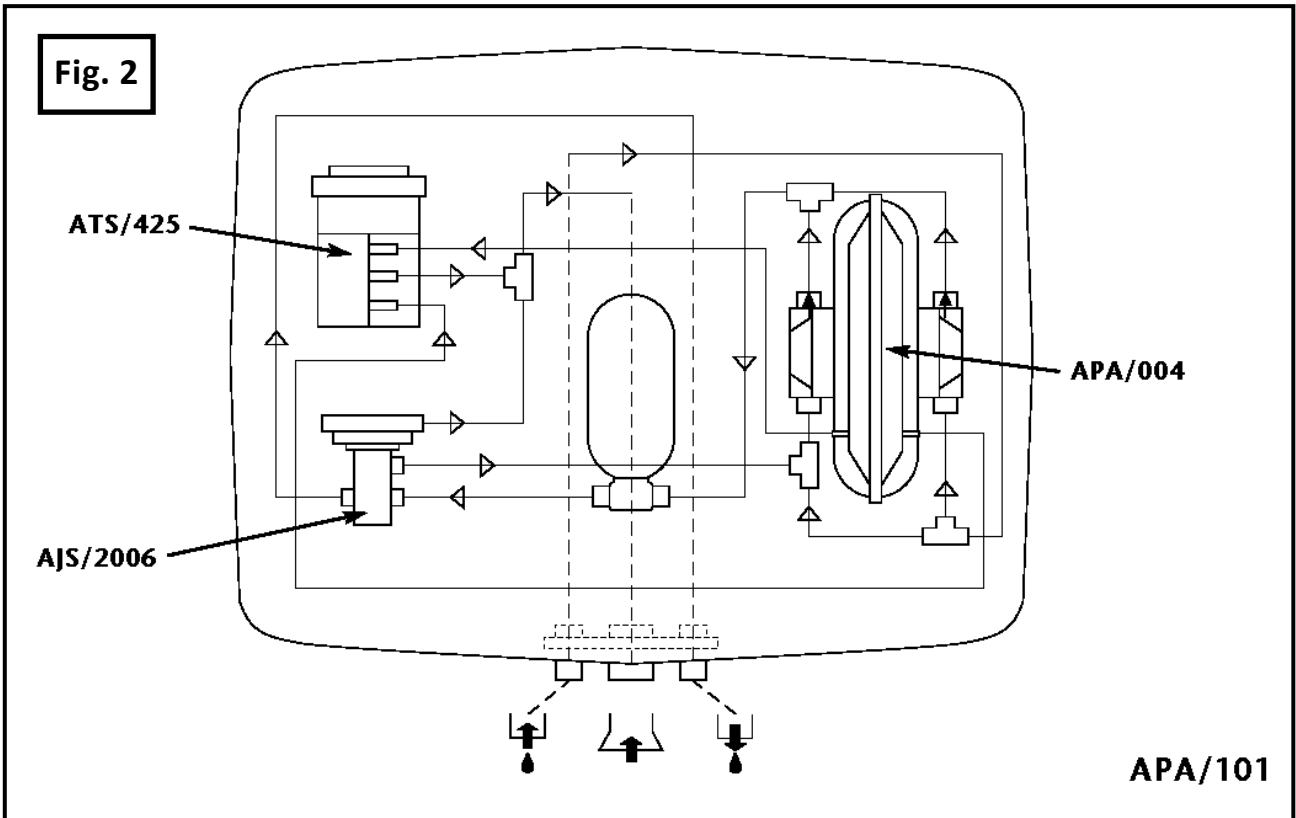

# 1. INSTALLATION

## SAFETY

The PeraSpray™ Cluster Spraying System is designed exclusively for use in milking installations. Any application outside the use described in this operating manual will be taken to be not in accordance with the intended purpose. The manufacturer/supplier will not be held responsible for any losses arising as a result of such use. The user will take full responsibility for use. **USE IN ACCORDANCE WITH THE INTENDED PURPOSE ALSO INCLUDES COMPLYING WITH THE OPERATING MANUAL AND THE CONDITIONS FOR INSPECTION AND MAINTENANCE.**

**ATTENTION!** Whilst in operation the installation is under an operating pressure of 3 to 4 bar! Do NOT spray chemical into your eyes! If you do, rinse with copious amounts of water and seek medical attention!

For general parlour layout refer to Fig. 1. Position Power Unit (A) not more than 3 metres (10ft) above the base of the Chemical Container, preferably in a dust free environment, close to a regulated Vacuum Line. The unit will slot onto some existing Wall Brackets. If this is a new system, fix using 2 x screws and rawlplugs. Using the drilling template on page 8, fit one screw first then carefully mark and drill the other. Accuracy between centres is most important.

**VACUUM SUPPLY** Drill a 10mmØ (3/8" Ø) hole in the top of a regulated main vacuum line (Fig. 3). Remove burrs, lubricate Pipe Adaptor (B) and twist into hole. Secure Tube (E) with Cable Ties (K). Do not over-tighten and avoid sharp bends. Cut tube to correct length and push firmly into Manifold rubber sleeve (Fig. 6 'A').

**CHEMICAL INTAKE** Unscrew Nut and remove Blanking Plug from intake port  (Fig. 2). Cut tube (C) to correct length ensuring that the Intake Filter (D) rests on the bottom of the Chemical Container. Insert tube through nut, warm end of tube to ease assembly and push fully onto port. Tighten nut firmly with fingers. Do not use pliers or other tools. This method should be used when connecting all such fittings on PeraSpray™ (Fig. 5).

**PRESSURE LINE** Determine position of 'T's (G) and strap loosely to a suitable support (Fig.4).

Cut suitable lengths of Tubing (F) strapping and connecting to 'T's (G) and outlet port  (Fig. 2). Plastic Hanging Hook (L) may be fitted to a suitable horizontal tube using 2 cable ties (K) or can be drilled with 2 holes and fitted (by 2 screws or bolts) to a flat surface. It is so designed that the cup of the applicator can rest in the Plastic Hanging Hook. Attach Coils (I) and Applicators (H). Seal open end of last 'T' with Blanking Plug (J) and Nut. Finally, once positions are correct, fully tighten Cable Ties. Do not over-tighten on tubing and avoid sharp bends.

## 2. INITIAL START UP

When installation is complete, turn on the Vacuum Pump. Power Unit will automatically start, reaching full pressure within one minute. There will be some air in the system. To expel this, hold each applicator above the Delivery Line vertically at arms length pointing away from face. Press button until air bubbles are no longer apparent.

PeraSpray™ is ONLY suitable for use with DILUTE solutions ( $\leq 250$  ppm or 0.025%) of Peroxyacetic Acid (Peracetic Acid); its use with certain other chemicals may invalidate warranty – please check with your Ambic dealer. When diluting concentrated chemical, ensure that the chemical manufacturer's instructions are followed precisely. The maximum concentration of Peracetic Acid that can be used is subject to regulations that differ between countries. Please check whether any local restrictions apply before use.

**Important:** Replenish disinfectant supply before it runs out to prevent air entering the system.

## 3. OPERATION

**SPRAYING** For effective cluster disinfection, a fresh solution of Peracetic Acid should be made up for each milking and the inside surfaces of each liner should be thoroughly sprayed. Immediately after each cow has finished milking, hang up the clusters so that the liners are hanging with open ends facing downwards. Position the spray nozzle of the applicator so that it is just inside the mouthpiece of the liner. Depress the lever for at least 1 second per liner, spraying each liner in turn.

**END OF MILKING** When the main Vacuum Supply is turned off, the Power Unit automatically returns pressurised disinfectant to the Chemical Container. This ensures immediate safety and also flushes any debris from the Intake Filter (D).

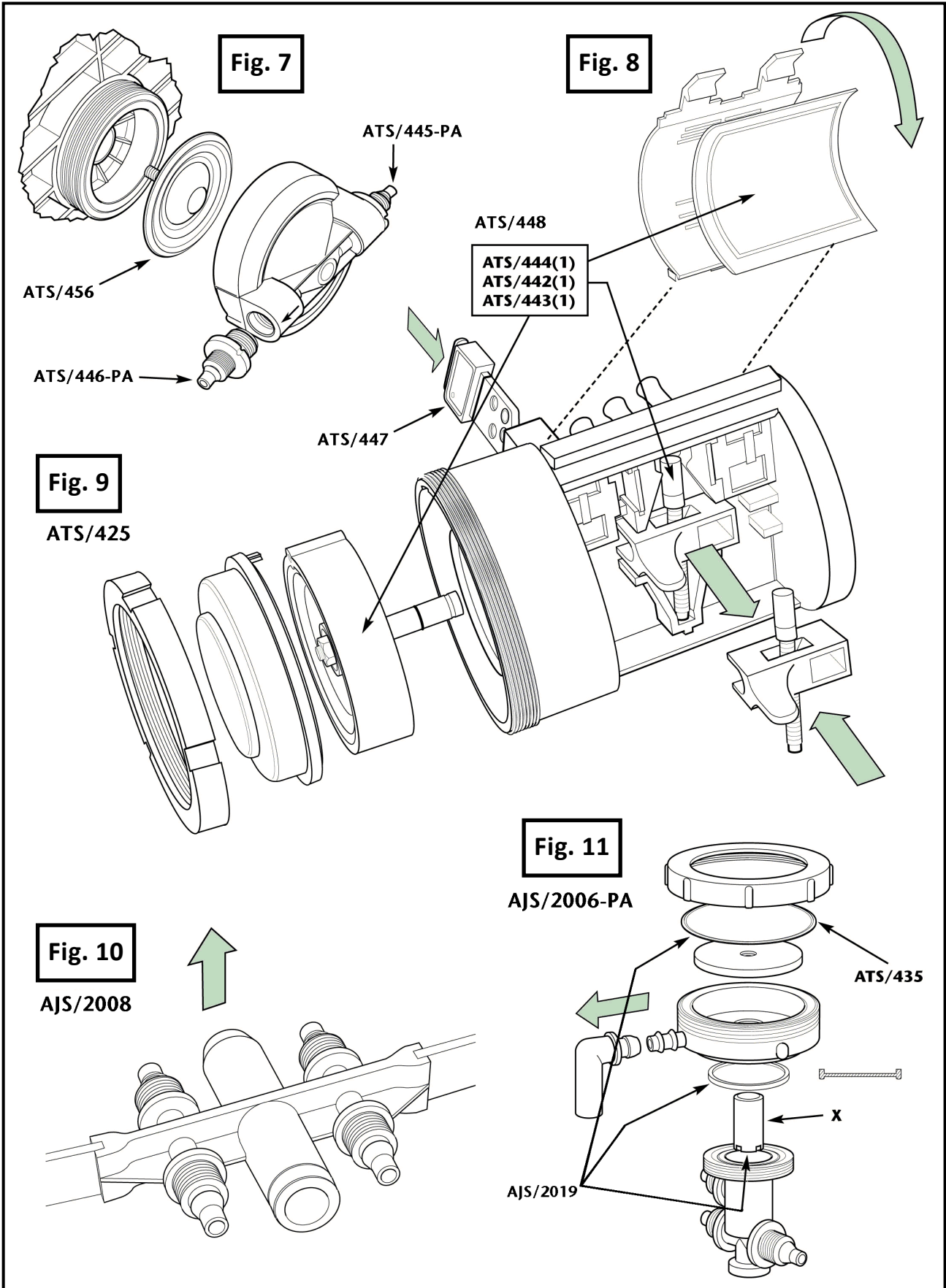

## 4. MAINTENANCE

**DIRECTIONAL VALVE ATS/425** is located at the top left of the Power Unit (Fig. 2).

**NOTE:** Most maintenance can be carried out with the Valve in place. If complete removal is required, slide out of clips using a twisting action (Arrow 1 Fig. 12). Grasp Valve Manifold and gently pull away from the Valve (Arrow 2 Fig. 12). To refit, reverse the operation.

**VALVE FILTER ATS/444** Replace every 1000 hours or sooner if heavily contaminated. Manually release Valve Filter Cover Clips by levering with fingers (Fig. 8). Carefully remove Valve Filter taking care not to drop dust into the working parts. Fit new Valve Filter by reversing the process.

**BLEED INSERT ATS/447** Pull out of main body taking care not to dislodge the 4 'O' Rings. Inspect two small holes near the end (Fig. 9). Clean every 1000 hours or sooner if heavily contaminated. Use strand of wire attached to bleed insert.

**DIAPHRAGM ASSEMBLY ATS/443** Replace every 3000 hours. First remove Valve Filter (see above). Remove Spring ATS/442. Pull Drive Box in direction of Arrow (Fig. 9) using pliers on lug. Unscrew large black ring nut, gently prise off red cap, using a screwdriver in slot provided. Pull out Rubber Diaphragm by grasping outer rim. Refit Diaphragm Assembly ATS/443 taking care not to remove the pre-lubrication on the shaft. If the Spring, ATS/442, shows any sign of corrosion replace it. Fit new Diaphragm Assembly by reversing the operation, ensuring that the semi-circular location engages in the recess on the main body. When replacing the Drive Box push hard until a click is heard indicating proper engagement. Prior to fitting the Filter and Cover, push Drive Box from end to end. An audible click should be heard, indicating proper operation.

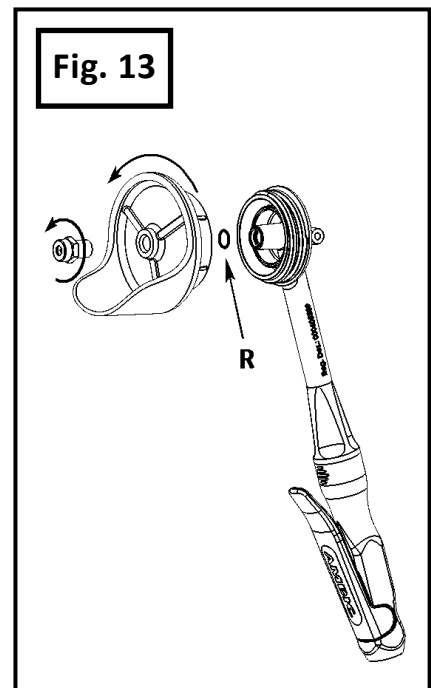
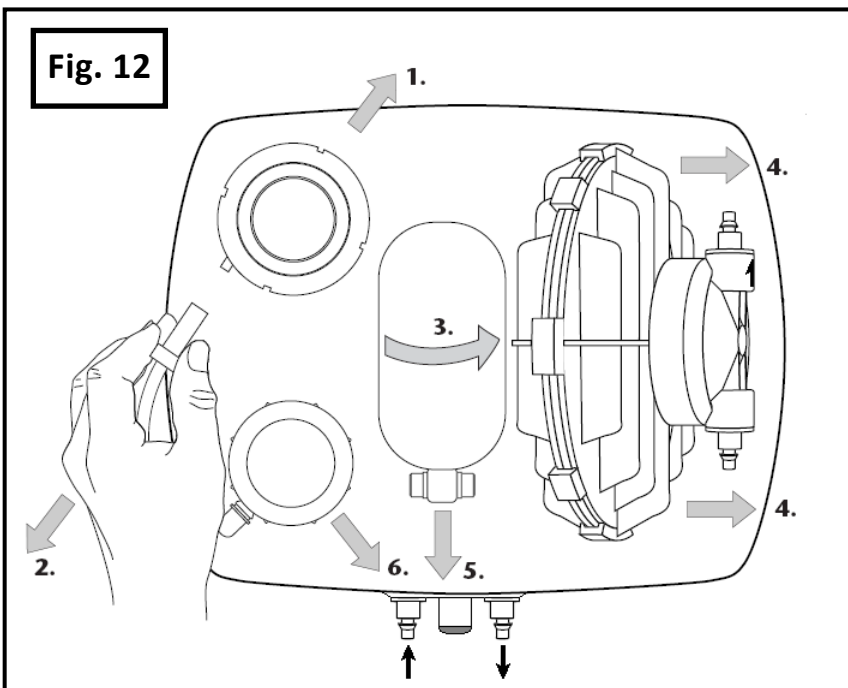

**DIAPHRAGM PUMP APA/004** The Pump is located on the right of the Power Unit 'A' (Fig. 2). It needs no maintenance but, in the rare event of failure, it is removed by first unscrewing the Pressure Bottle ATS/436 in the direction of arrow 3 (Fig. 12). Remove transit fixings. Tilt Pump APA/004 and unclip by sliding in the direction of arrows 4 (Fig. 12). Remove both rubber elbows. Unscrew 4 Nuts, on the Pump Head, ATS/445-PA and ATS/446-PA (Fig. 7), warm Tube ends and pull off gently, noting their positions. When replacing the Pump, make sure that the arrows on the Pump Heads point towards the top of the Power Unit. Occasionally, debris may enter the Non-Return Valves ATS/445-PA and ATS/446-PA (Fig. 7). These can be unscrewed using the AmbiSpanner™ provided, or long nosed pliers. Wash out and blow through. These components can be replaced if damaged.

**RELIEF VALVE AJS/2006-PA** is located at bottom left of Power Unit (Fig. 2). To replace Diaphragm ATS/435, unscrew top with moulded lugs, this will expose Diaphragm for replacement. To fit a different Pressure Relief Module 'X' (Fig. 11), AJS/2016, remove rubber elbow in direction of arrow. Unscrew the complete top inclusive of Spigot section, this will expose the existing Relief Module. To replace or remove complete Relief Valve, first remove the Pump as described under Diaphragm Pump. Then tilt and slide Bottle Holder in direction of arrow 5 (Fig. 12), unclip the Relief Valve in direction of arrow 6. Unscrew 3 nuts on the Relief Valve, warm tube ends and pull off gently noting their positions.

**MANIFOLD ASSEMBLY AJS/2008** is located by friction fit in the skirt of the Case Base (Fig. 10). If it is damaged it can be replaced. Unscrew 4 Nuts and remove tubes. Pull out Vacuum Pipe 'A'. Cut Vacuum Pipe 'B' (Fig. 6) close to rubber bush as it is glued for transportation. Lever the Manifold from Case Base. Replace with new unit. Both Vacuum Pipes 'A' & 'B' need only be pushed in.

## 5. TROUBLE SHOOTING

FAULT	CAUSE	REMEDY
<b>1. Unit does not spray</b>	<ul style="list-style-type: none"> <li>a. Vacuum Pump not switched on</li> <li>b. Vacuum line not airtight</li> <li>c. Constricted Vacuum Supply Pipe (E)</li> <li>d. Chemical Container is empty</li> <li>e. Intake Filter (D) blocked</li> <li>f. Pressure Line (F) blocked</li> <li>g. Spray Nozzle APA/015 blocked</li> <li>h. Unsuitable chemical being used</li> <li>i. Pump APA/004 faulty</li> <li>j. Directional Valve ATS/425 faulty</li> <li>k. Relief Valve AJS/2006-PA faulty</li> </ul>	<ul style="list-style-type: none"> <li>a. Switch on Vacuum Pump</li> <li>b. Check that Vacuum is reaching Power Unit by pulling Supply Pipe out and test with finger. Check Vacuum Pipe adaptor is correctly installed</li> <li>c. Check for kinks and overtightened Cable Ties</li> <li>d. Fill Container</li> <li>e. Clean Filter</li> <li>f. Clear blockage, check for constrictions, kinks and tight Cable Ties</li> <li>g. Disassemble (see Fig. 13), clean Nozzle</li> <li>h. Change to appropriate Disinfectant</li> <li>i. Check Pump and repair or replace</li> <li>j. Check Valve and repair or replace</li> <li>k. Check Valve and clean, repair or replace</li> </ul>
<b>2. Nozzle (Fig.13) does not shut off cleanly or Leaks</b>	<ul style="list-style-type: none"> <li>a. Air in pressure Line (F)</li> <li>b. Control Valve ATS/405-PA dirty or damaged</li> </ul>	<ul style="list-style-type: none"> <li>a. Vent as described under "2. Initial start up"</li> <li>b. Clean or replace Control Valve</li> </ul>
<b>3. Chemical running out of Power Unit</b>	<ul style="list-style-type: none"> <li>a. Loose Connector Nut</li> <li>b. Defective Pump or Relief Valve</li> </ul>	<ul style="list-style-type: none"> <li>a. Locate leak and tighten Nut</li> <li>b. Check Units and repair or replace</li> </ul>
<b>4. Unit pressurised when Vacuum switched off</b>	Relief Valve faulty	Repair or replace
<b>5. Chemical leaks into Vacuum line</b>	Relief Valve or Pump faulty	Immediately disconnect Vacuum line & plug it. Repair or replace defective parts.

## 6. TECHNICAL DATA

Power Source	Vacuum 12-15 in Hg (40-50 kPa)	Maximum No. of applicators operated simultaneously	3
Chemical Consumption	30-45 ml/s per applicator	Maximum No. of applicators per Power Unit	50
Air Consumption	50 l/min (1.8cfm Atmospheric Air @ 50kPa)	Maximum length of Pressure Line	25 m 80 ft
Spray Pressure	50 psi (3.4 Bar) @ 46kPa (13.5 in Hg)	Operating Temperature	(min.) 5 °C (max.) 40 °C

7. SPARE PARTS • PIÉCES DÉTACHÉES  
ERSATZTEILE • REPUESTOS

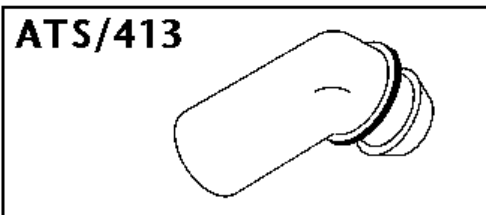
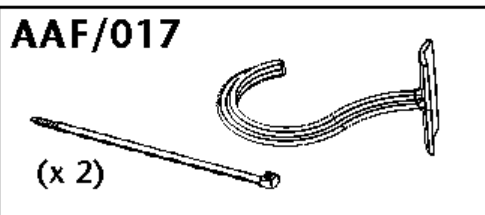
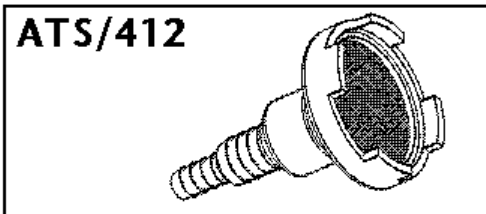
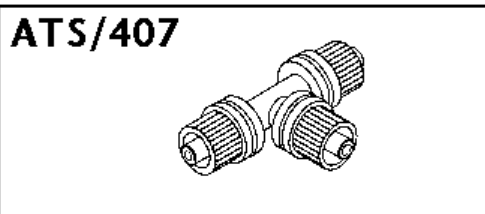
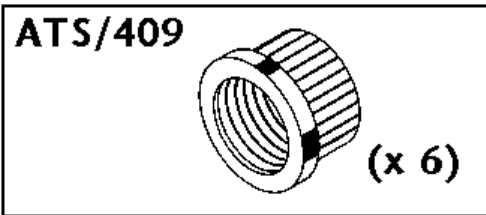
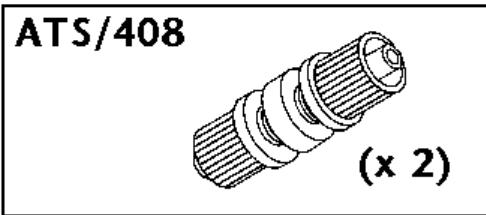
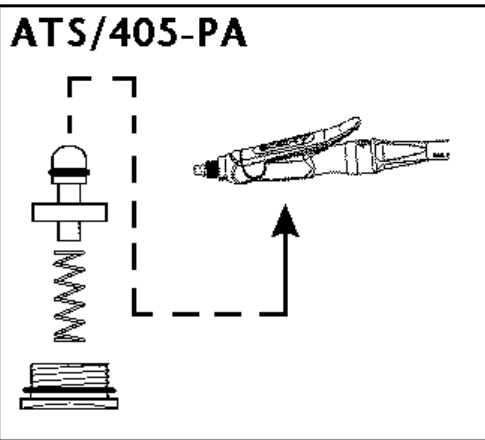
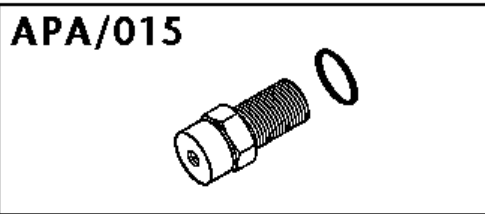
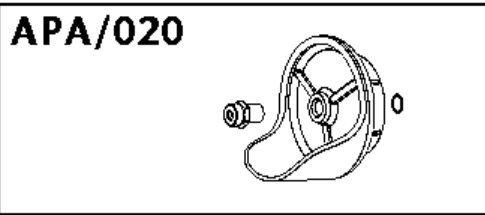
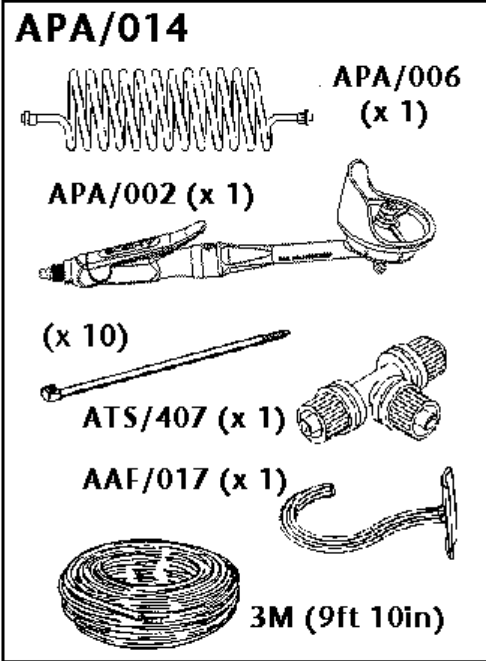
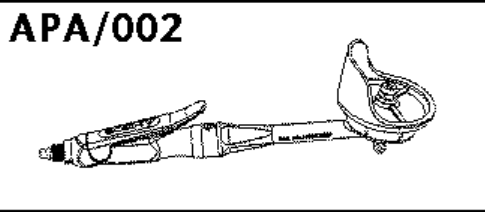
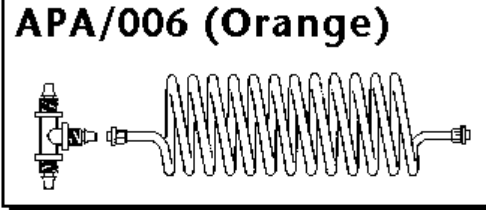

NOTE – Not all parts are illustrated – please contact your Ambic Dealer

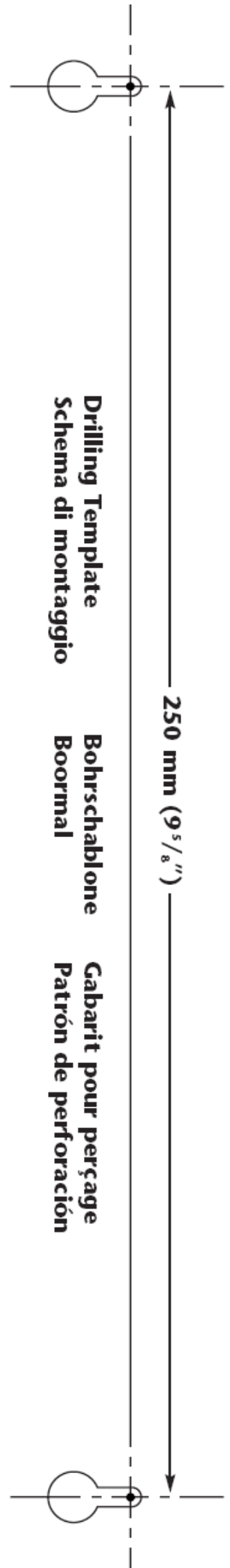

Ambic Equipment Limited,  
 1 Parkside, Avenue Two, Station Lane, Witney, Oxfordshire,  
 OX28 4YF, England  
 Tel: +44 (0)1993 776555 Fax: +44 (0)1993 779039  
[www.ambic.co.uk](http://www.ambic.co.uk)